

INSTRUCTIONS

MODEL 3009 SERIES II IMPROVED

SME

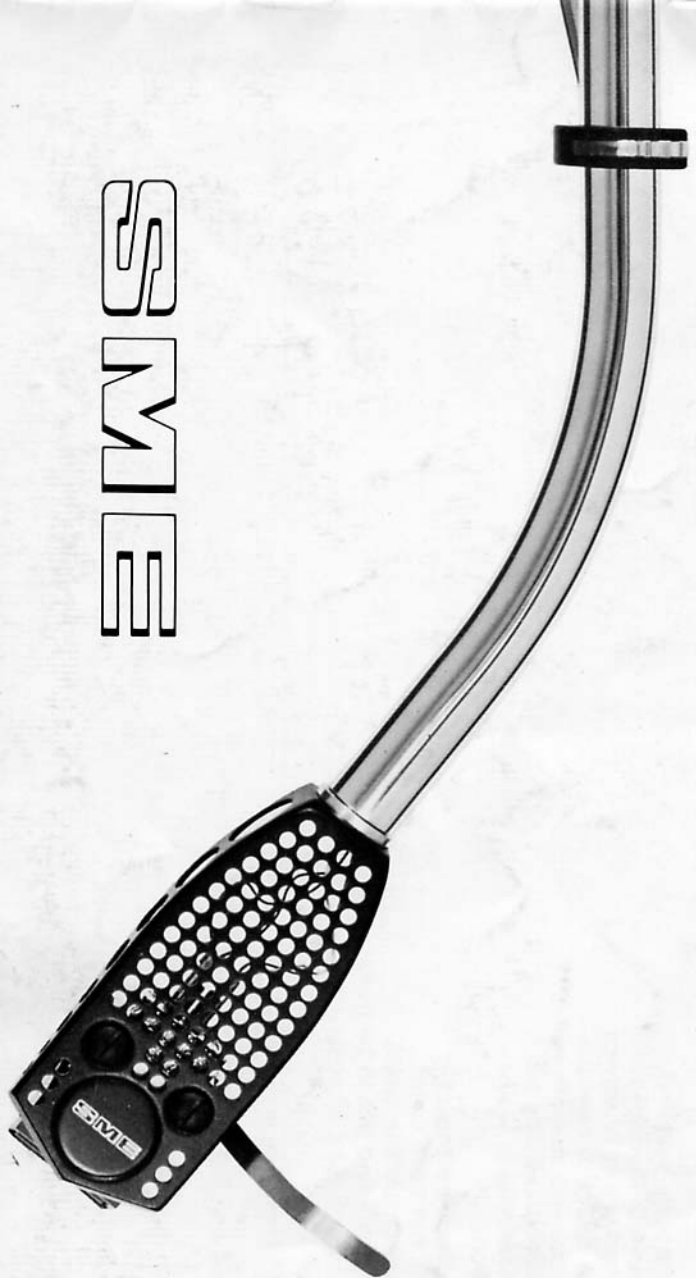

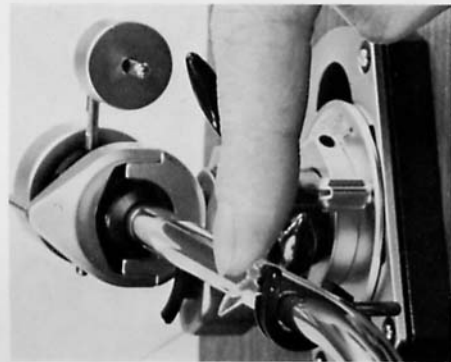

139

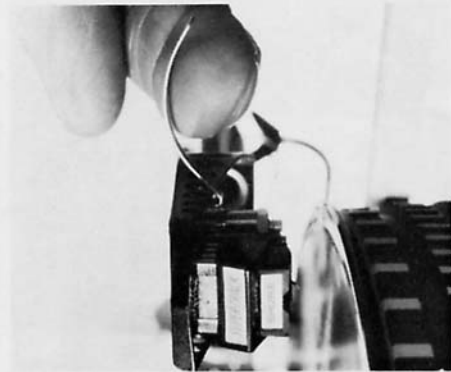

140

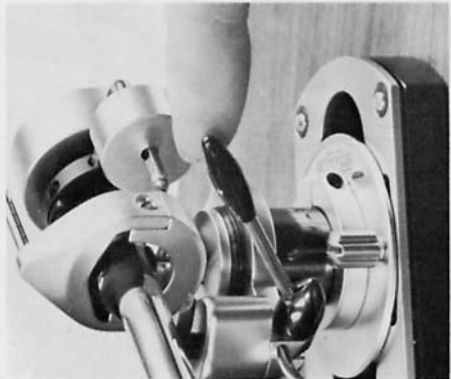

141

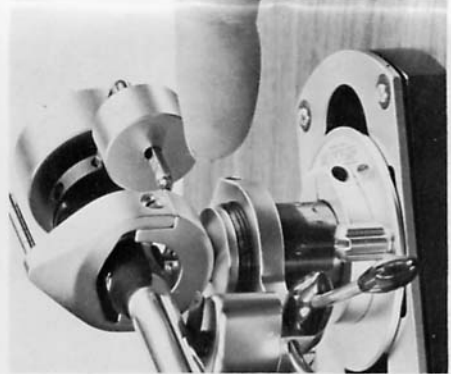

142

Operation

139 With the control lever raised release the tone-arm from its rest.

140 Place the stylus over selected band on the record.

141 Move the control lever forward

142 allowing it to fall freely.

After playing, raise the control lever to lift the stylus from the record. Return the arm to its rest.

SME Model 3009 Series II Improved precision pick-up arms combine latest design features with the same high quality engineering and finish that made their predecessors famous for more than a decade.

Each arm is meticulously built and tested and will meet its specification reliably through many years of service. Skilful design and choice of materials combine high mechanical strength with low inertia and friction ensuring full suitability for professional as well as domestic application.

Technically correct and aesthetically satisfying the SME has been called "The best pick-up arm in the world" and we believe you will find this to be true.

CONTENTS

Page	
4	Setting out
5	Fitting the Arm
6	Fitting the Cartridge
7	Model 3009/S2 Improved (detachable shell)
8	Audio Lead
9	Pillar Adjustment
10	Shell Adjustment
11	Tracking Adjustment
12	Balance Adjustment
13	Bias Adjustment
14	Operation

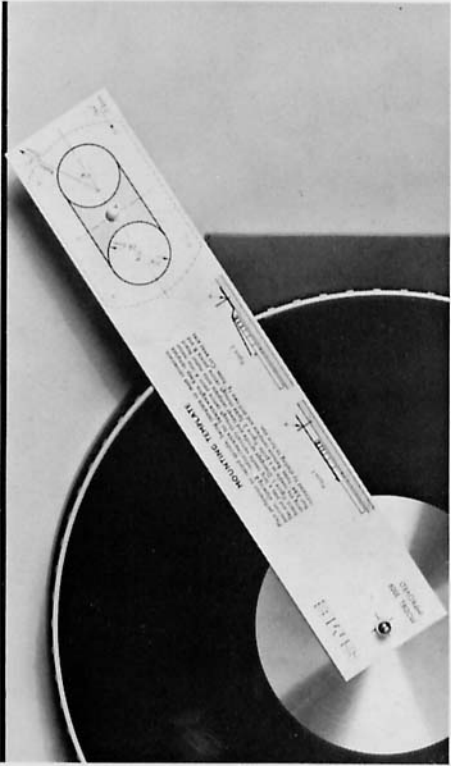

101

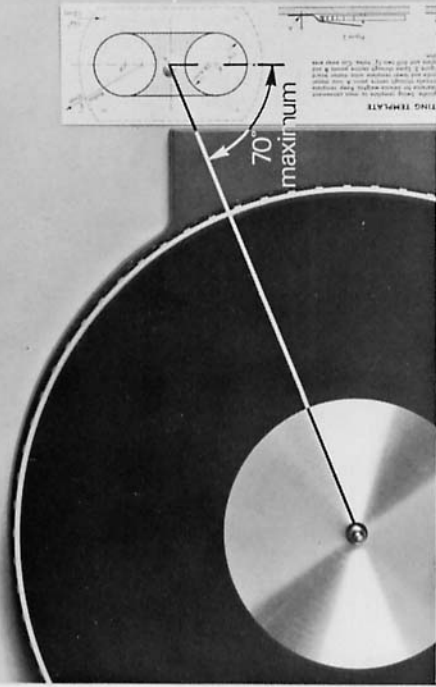

102

Setting out

101 Establish the position for the bedplate with the mounting template.

102 Where space is restricted the template may be rotated up to 70° off the radial position.

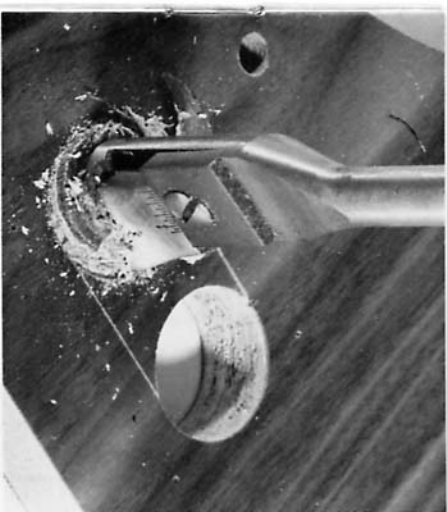

103

Fitting the arm

103 Drill and form the cut-out in accordance with the template. Ensure that it is large enough to clear the screening can completely. Drill the four $\frac{3}{8}$ " (1.2 mm.) pilot holes for the wood-screws.



104

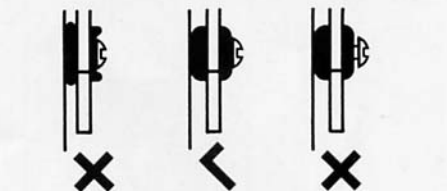

105

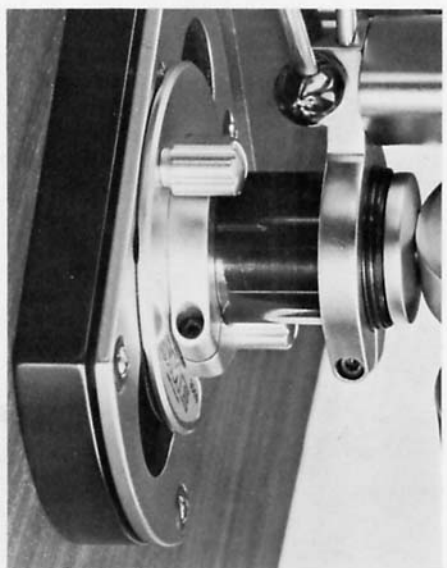

106

106 When the surface of the turntable is more than $1\frac{1}{8}$ " (41 mm.) above that on which the bedplate is mounted a spacer SME Accessory P.1 is required.

104 Screw down the bedplate with the four wood-screws.

105 Adjust the screws as shown.



107

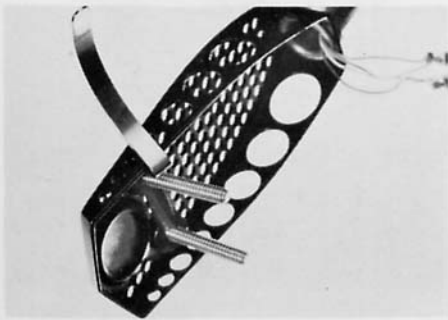

108

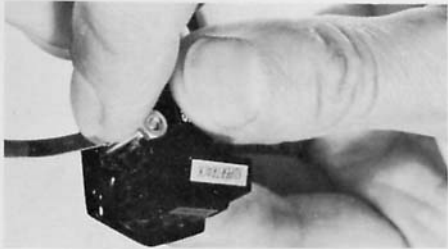

109

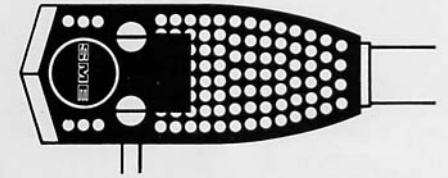

110



111

Fitting the cartridge

107 Fit the pin jacks to the cartridge terminals: White to left channel; Red to right channel; Blue to left ground; Green to right ground. Tails must never be soldered direct to the cartridge terminals.

108 Select screws of appropriate length. The top of the cartridge should lie snugly against the shell or as close to it as possible. The use of the finger lift is optional. Use spacers only if cartridge contours make it essential.

109 Fit the nuts.

110 Check that the cartridge lies symmetrically in the shell. This is important.

111 Tighten the screws taking care to preserve (110)

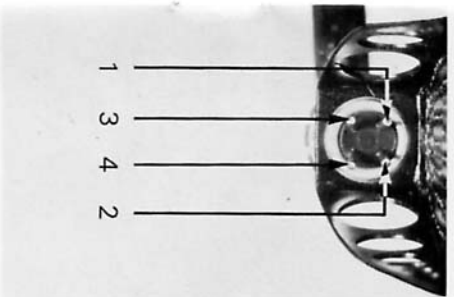

1
3
4
2

112

**Model 3009/S2 Improved
(detachable shell)**

112 Fit the tails to the shell terminals:
White (1) to left channel; Red (2) to
right channel; Blue (3) to left ground;
Green (4) to right ground. Fit the
cartridge as detailed on Page 6.

113 Insert the shell in the arm socket.

114 Press in to contact the thread.

115 Maintaining pressure, rotate the
socket nut to draw the shell firmly
home. Do not over-tighten.



113

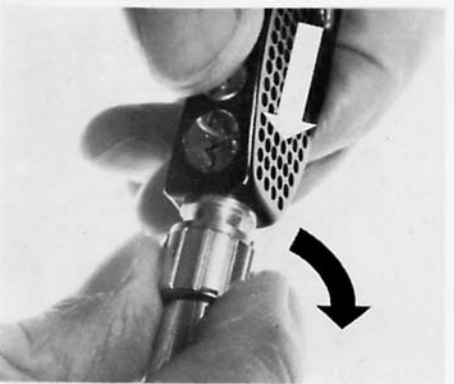

114

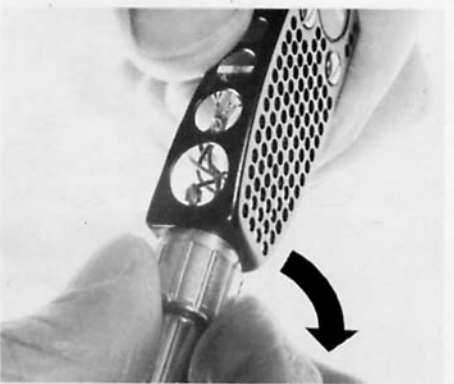

115



116

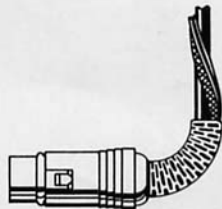

117

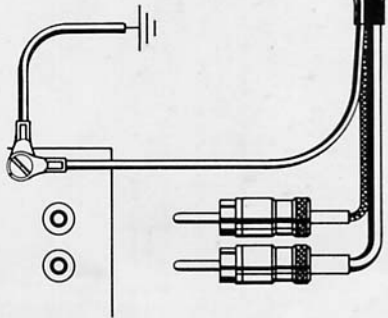

Audio Lead

116 Leads with 5-pole DIN plug make ground connection automatically.

117 Leads with phono plugs are coded White (L) for left channel and Red (R) for right channel. The ground wire should be connected to a terminal or screw on the amplifier chassis.

118

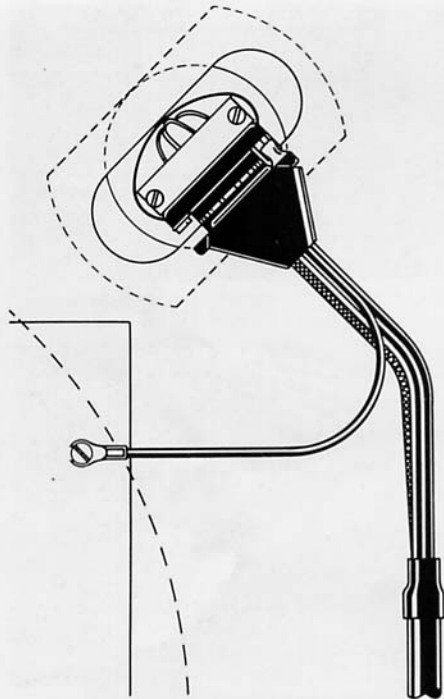

118 Insert the output plug into the output socket beneath the arm. Connect the ground wire to a suitable terminal or screw on the turntable chassis.

Note: There must be no other ground connections and the system must be connected to main ground by one path only, usually from the amplifier to the third pin of the mains. Additional paths to ground will increase hum.



119

Pillar adjustment

119 Release the cap screw in the base to unlock the pillar.

120 Rotate the pillar to position the arm-rest in a convenient position relative to the turntable.

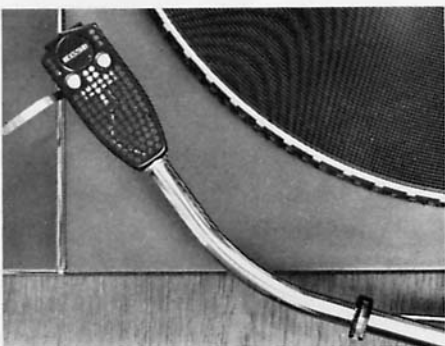

120

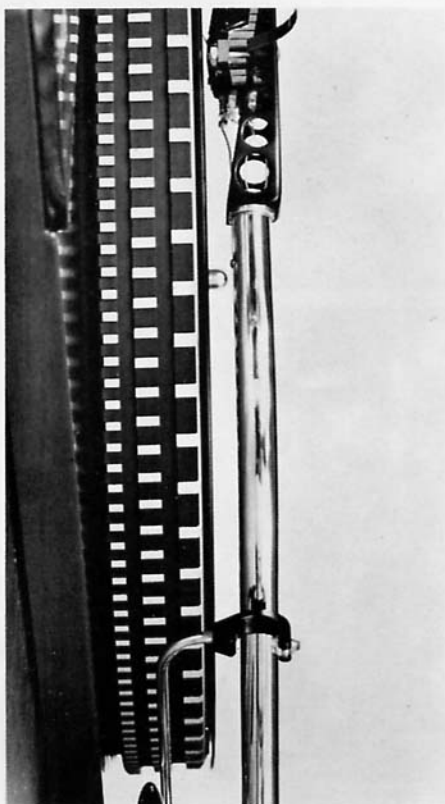

121

121 Set the pillar height so that the arm is parallel with the record surface when playing. Check that there is clearance between the tone-arm and the rubber surface of the lowering and raising control when the lever is in the down position. If one does not clear the other, the pillar is set too high. Relock the cap screw.

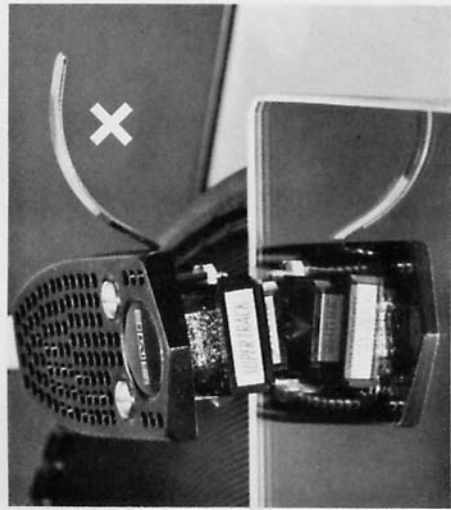

122

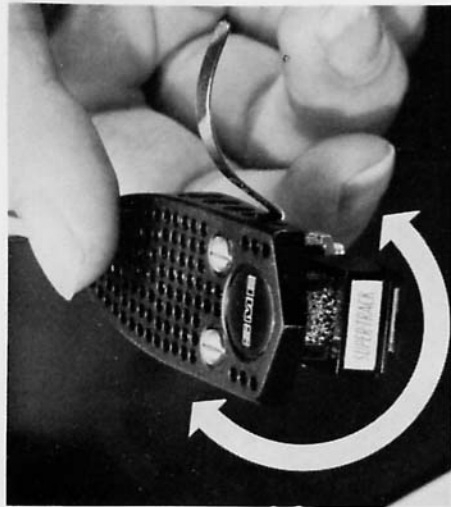

123

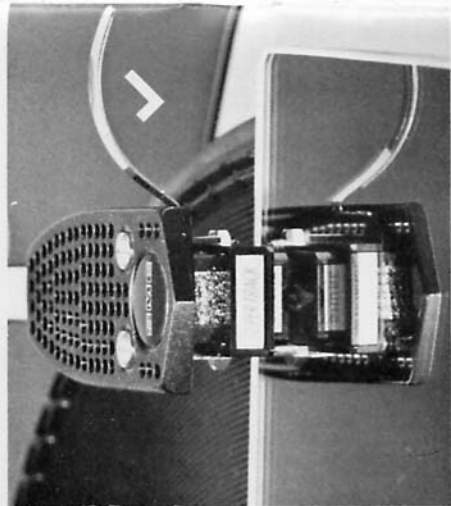

124

Shell Adjustment

122 Place a small flat mirror on the turntable and rest the stylus on it.

123 If necessary hold the shell firmly close to the tone-arm and twist in the required direction with one hand whilst holding the arm firmly with the other. *The stylus must be clear of the mirror whilst this is done.* Movement of the socket in the end of the tone-arm is limited by a detent screw.

124 Recheck with the mirror.

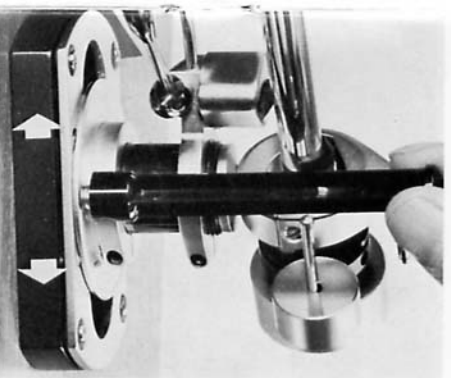

125

125 Release the base clamp nuts with the plastic box spanner.

126

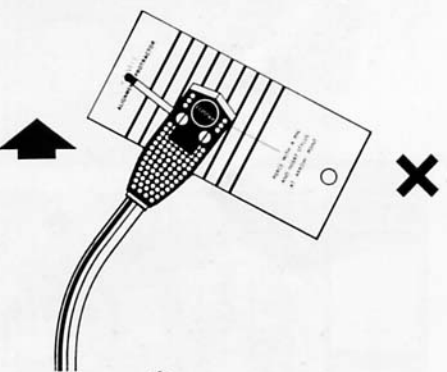

127

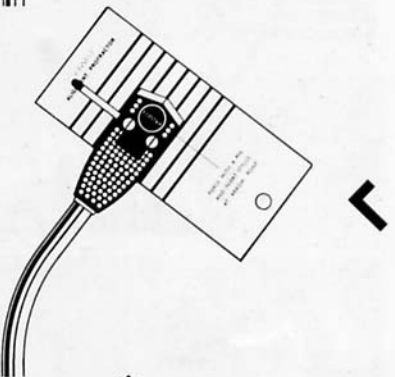

128

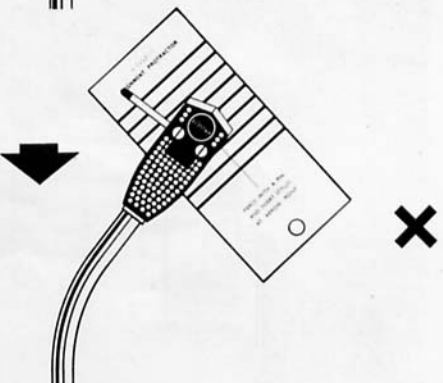

Tracking adjustment

- 126 Place a record on the turntable
- 127 with the alignment protractor on top of it. The large hole engages the record spindle with the stylus in the small one. Move the base on the bedplate until the cartridge and shell appear symmetrical with the protractor. Relock the base clamp nuts.

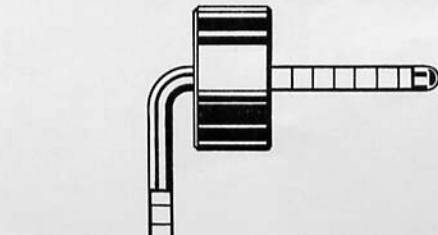

129

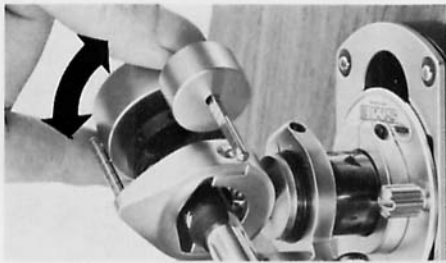

130



131

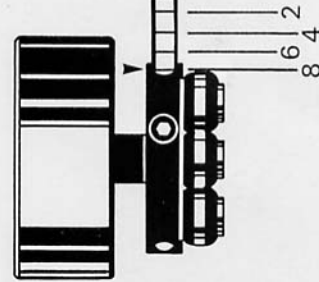

132

Balance adjustment

129 Position the rider weight so that its front coincides with the first division of the wayrod.

130 Place the arm in a state of equilibrium by rotating the balance weight in the required direction.

131 Release the set screw in the wayrod housing.

132 Divisions correspond to cartridge weights in grams. Adjust as required for your cartridge. The setting shown is for 8 grams.

Relock the set screw.

133 Apply tracking force by advancing the rider weight along the wayrod. Each division travelled applies $\frac{1}{4}$ (.25) gram tracking force at the stylus.

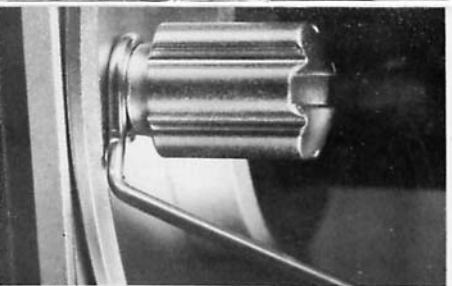

134

Bias adjustment

134 Fit the eye of the bias guide under the base clamp nut nearest to the turntable.

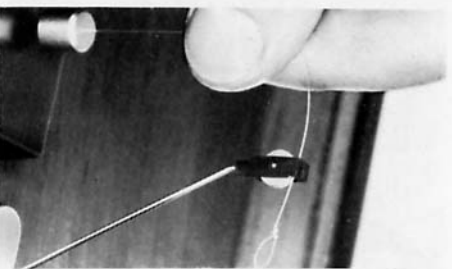

135

135 Thread the nylon through the guide pulley housing and pass **136** the loop over the bias lever.



136

138 Position the bias guide so that the thread is at approximately 90° to the bias lever when the stylus is over the outer groove of a 12" record. Rotate the guide pulley housing to align it with the thread which must lie in the groove of the pulley.

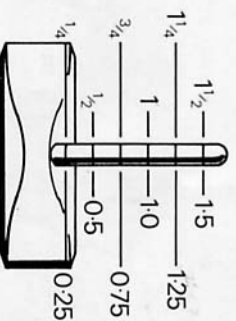

We hope these instructions have made the installation of your SME precision pick-up arm simple and straightforward. Care for it much as you would a camera. Do not attempt to take it to pieces. Do not apply oil or other lubricant to any part of it. If you have a problem concerning its operation or repair write to the address overleaf. We provide quick and efficient service direct from the factory to any part of the world. In the first instance please write, do not send us the arm unless requested to do so.

The Company's policy is the continuous improvement of its products. We therefore reserve the right of any departure from illustration or specification herein that this may occasion.